

HSK-E

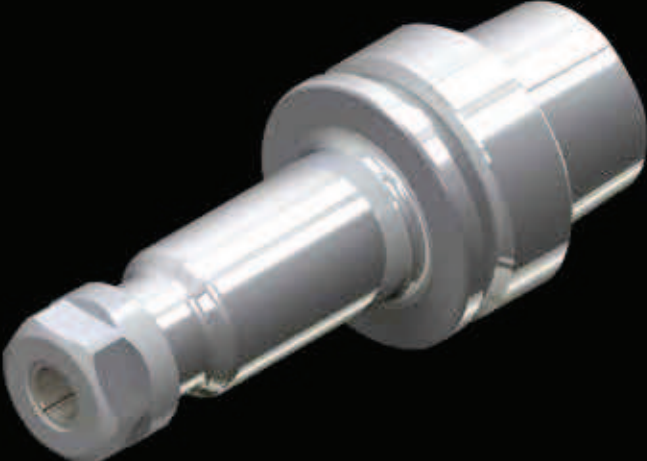

HSK-F

HSK是中空短圓錐刀桿

始於1991年德國阿亨大學開發

1993年成為德國規範DIN69893-1~6:1993

共有A, B, C, D, E & F六種錐度形式

2001年成為ISO規範ISO12164-1:2001

並將原本1/10的錐度改為1/9.98

確保錐度與端面兩面接觸時

中空短圓錐的大端能確實接觸

HSK is hollow shank short taper toolholders

It was developed by Achen University in Germany in 1991

In 1993, Germany published it as norm DIN69893-1~6:1993

There are six different type of HSK: A, B, C, D, E & F

In 2001, ISO published it as norm ISO12164-1:2001

ISO revised the taper angle from 1:10 to 1:9.98

It was to make sure the taper D2 will contact the spindle when HSK toolholder has dual contact on taper and face

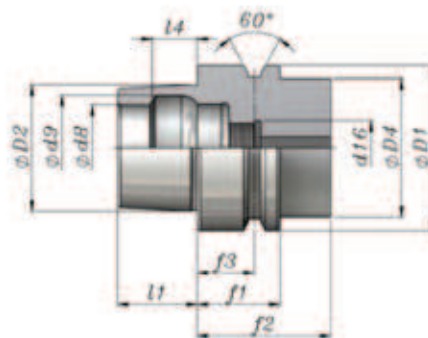

CLAMPING FORC	HSK-E025	HSK-E032	HSK-E040	HSK-E050	HSK-E063
	2.8KN	5KN	6.8KN	11KN	18KN

TAPER	HSK-E025	HSK-E032	HSK-E040	HSK-E050	HSK-E063
ØD1 h10	25		40	50	63
ØD2	19 +0.006/+0.004	24 +0.007/+0.005	30 +0.007/+0.005	38 +0.009/+0.006	48 +0.011/+0.007
ØD4 max.	20		34	42	53
Ød8 H10	14		21	26	34
Ød9 H11	16.4		25.5	32.0	40.0
d16	M10*P1.0	M10*P1.0	M12*P1.0	M16*P1.0	M18*P1.0
f1 0.0/-0.1	10		20	26	26
f2 min.	20		35	42	42
f3 +/-0.1	4.5		16.0	18.0	18.0
l1 0.0/-0.2	13		20	25	32
l4 JS10	7.21		11.42	14.13	18.13

Shrink fit chucks

熱膨脹燒結刀桿

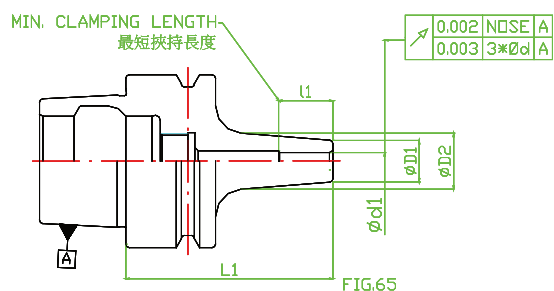

動平衡G2.5/25,000RPM或小於1gmm // BALANCE TO G2.5/25,000RPM OR UNDER 1gmm

STOCK	CODE	FIG.	L1	L2	ØD1	ØD2	ØD3	Ød	l1-min. 最短夾持長度 Min. Clamping Length	l2-max. 最長夾持長度 Max. Clamping Length	止動螺絲 (M) Screw Page 153	重量 (KG) Weight
	HSK-E032-EZ03-060	65	60	-	15	20	-	3	15	-	-	0.20
	HSK-E032-EZ04-060	65	60	-	15	20	-	4	15	-	-	0.20
	HSK-E032-EZ05-060	65	60	-	15	20	-	5	17	-	-	0.20
STOCK	CODE	FIG.	L1	L2	ØD1	ØD2	ØD3	Ød	l1-min. 最短夾持長度 Min. Clamping Length	l2-max. 最長夾持長度 Max. Clamping Length	止動螺絲 (M) Screw Page 153	重量 (KG) Weight
	HSK-E040-EZ03-060	65	60	-	12	17	-	3	15	-	-	0.20
	HSK-E040-EZ03-080	65	80	-	15	20	-	3	15	-	-	0.40
	HSK-E040-EZ03-120	65	120	-	15	20	-	3	15	-	-	0.60
	HSK-E040-EZ04-060	65	60	-	12	17	-	4	17	-	-	0.20
	HSK-E040-EZ04-080	65	80	-	15	20	-	4	17	-	-	0.40
	HSK-E040-EZ04-120	65	120	-	15	20	-	4	17	-	-	0.60
	HSK-E040-EZ05-060	65	60	-	12	17	-	5	17	-	-	0.20
	HSK-E040-EZ05-080	65	80	-	15	20	-	5	17	-	-	0.40
	HSK-E040-EZ05-120	65	120	-	15	20	-	5	17	-	-	0.60
STOCK	CODE	FIG.	L1	L2	ØD1	ØD2	ØD3	Ød	l1-min. 最短夾持長度 Min. Clamping Length	l2-max. 最長夾持長度 Max. Clamping Length	止動螺絲 (M) Screw Page 153	重量 (KG) Weight
	HSK-E050-EZ03-060	65	60	-	12	17	-	3	15	-	-	0.50
	HSK-E050-EZ03-080	65	80	-	15	20	-	3	15	-	-	0.70
	HSK-E050-EZ03-120	65	120	-	15	20	-	3	15	-	-	0.90
	HSK-E050-EZ04-060	65	60	-	12	17	-	4	17	-	-	0.50
	HSK-E050-EZ04-080	65	80	-	15	20	-	4	17	-	-	0.70
	HSK-E050-EZ04-120	65	120	-	15	20	-	4	17	-	-	0.90
	HSK-E050-EZ05-060	65	60	-	12	17	-	5	17	-	-	0.50
	HSK-E050-EZ05-080	65	80	-	15	20	-	5	17	-	-	0.70
	HSK-E050-EZ05-120	65	120	-	15	20	-	5	17	-	-	0.90

STOCK ◎=標準在庫品 // STOCK ○=regular stock | STOCK ○=少量在庫品 // STOCK ○=few stock | STOCK無標示=接單生產品 // STOCK BLANK=on request

HSK-E-EZ

Shrink fit chucks

熱膨脹燒結刀桿

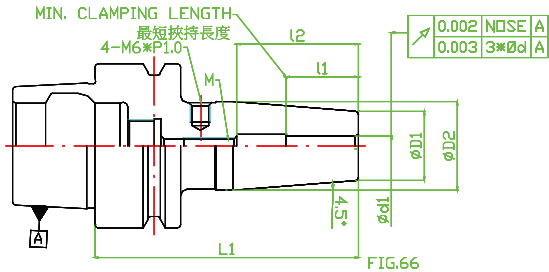

FIG.66

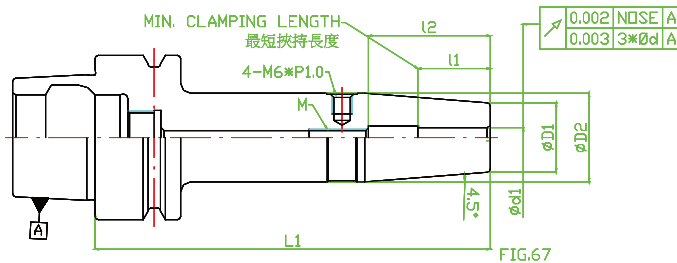

FIG.67



動平衡G2.5/25,000RPM或小於1gmm // BALANCE TO G2.5/25,000RPM OR UNDER 1gmm

STOCK	CODE	FIG.	L1	L2	ØD1	ØD2	ØD3	Ød	l1-min. 最短夾持長度 Min. Clamping Length	l2-max. 最長夾持長度 Max. Clamping Length	止動螺絲 (M) Screw Page 153	重量 (KG) Weight
	HSK-E032-EZ06-070	66	70	-	21	26	-	6	23	36	M5*P0.8	0.40
	HSK-E032-EZ08-070	66	70	-	21	26	-	8	23	36	M6*P1.0	0.40
	HSK-E032-EZ10-070	66	70	-	24	29	-	10	32	42	M8*P1.0	0.50
	HSK-E032-EZ12-070	66	70	-	24	29	-	12	37	47	M10*P1.0	0.50
STOCK	CODE	FIG.	L1	L2	ØD1	ØD2	ØD3	Ød	l1-min. 最短夾持長度 Min. Clamping Length	l2-max. 最長夾持長度 Max. Clamping Length	止動螺絲 (M) Screw Page 153	重量 (KG) Weight
	HSK-E040-EZ06-080	66	80	-	21	27	-	6	23	37	M5*P0.8	0.50
	HSK-E040-EZ06-120	67	120	-	21	27	-	6	23	37	M5*P0.8	0.80
	HSK-E040-EZ08-080	66	80	-	21	27	-	8	27	37	M6*P1.0	0.50
	HSK-E040-EZ08-120	67	120	-	21	27	-	8	27	37	M6*P1.0	0.80
	HSK-E040-EZ10-080	66	80	-	24	32	-	10	32	42	M8*P1.0	0.60
	HSK-E040-EZ10-120	67	120	-	24	32	-	10	32	42	M8*P1.0	0.90
	HSK-E040-EZ12-090	66	90	-	24	32	-	12	37	48	M10*P1.0	0.60
	HSK-E040-EZ12-120	67	120	-	24	32	-	12	37	48	M10*P1.0	0.90
	HSK-E040-EZ14-090	66	90	-	27	34	-	14	37	48	M10*P1.0	0.60
	HSK-E040-EZ16-090	67	90	-	27	34	-	16	40	51	M12*P1.0	0.60
STOCK	CODE	FIG.	L1	L2	ØD1	ØD2	ØD3	Ød	l1-min. 最短夾持長度 Min. Clamping Length	l2-max. 最長夾持長度 Max. Clamping Length	止動螺絲 (M) Screw Page 153	重量 (KG) Weight
	HSK-E050-EZ06-080	66	80	-	21	27	-	6	23	37	M5*P0.8	0.70
	HSK-E050-EZ06-120	67	120	-	21	27	-	6	23	37	M5*P0.8	1.00
	HSK-E050-EZ08-080	66	80	-	21	27	-	8	27	37	M6*P1.0	0.70
	HSK-E050-EZ08-120	67	120	-	21	27	-	8	27	37	M6*P1.0	1.00
	HSK-E050-EZ10-085	66	85	-	24	32	-	10	32	42	M8*P1.0	0.80
	HSK-E050-EZ10-120	67	120	-	24	32	-	10	32	42	M8*P1.0	1.10
	HSK-E050-EZ12-090	66	90	-	24	32	-	12	37	48	M10*P1.0	0.80
	HSK-E050-EZ12-120	67	120	-	24	32	-	12	37	48	M10*P1.0	1.10
	HSK-E050-EZ14-090	66	90	-	27	34	-	14	37	48	M10*P1.0	0.80
	HSK-E050-EZ16-095	67	95	-	27	34	-	16	40	51	M12*P1.0	1.10
	HSK-E050-EZ18-095	66	95	-	33	42	-	18	40	51	M12*P1.0	0.90
	HSK-E050-EZ20-100	67	100	-	33	42	-	20	42	53	M16*P1.0	0.90

產品 FIG.66 & 67 出貨附件為長度調整螺絲 BK-EZ-Mxx*1pc // PRODUCTS IN FIG.66 & 67 EQUIP WITH BACK UP SCREW BK-EZ-Mxx*1PC
 STOCK ⊙=標準在庫品 // STOCK ⊙=regular stock | STOCK ○=少量在庫品 // STOCK ○=few stock | STOCK 無標示=接單生產品 // STOCK
 BLANK=on request

■ SlimSuper shrink fit chucks

● 超細型熱膨脹燒結刀桿

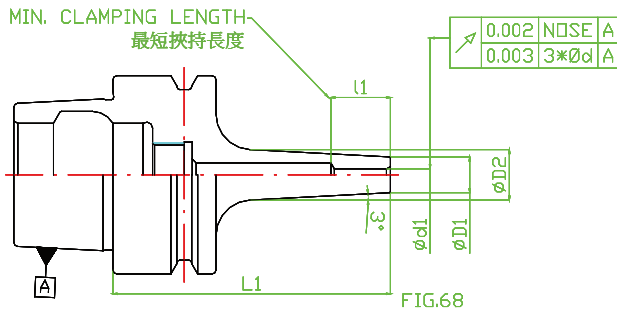

動平衡G2.5/25,000RPM或小於1gmm // BALANCE TO G2.5/25,000RPM OR UNDER 1gmm

STOCK	CODE	FIG.	L1	L2	ØD1	ØD2	ØD3	Ød	I1-min. 最短夾持長度 Min. Clamping Length	I2-max. 最長夾持長度 Max. Clamping Length	止動螺絲 (M) Screw Page 153	重量 (KG) Weight
	HSK-E025-EZ03SS-045	68	45	-	9	12.5	-	3	15	-	-	0.10
	HSK-E025-EZ03SS-055	68	55	-	9	13.5	-	3	15	-	-	0.15
	HSK-E025-EZ03SS-070	68	70	-	9	15	-	3	15	-	-	0.20
	HSK-E025-EZ04SS-045	68	45	-	10	13.5	-	4	17	-	-	0.10
	HSK-E025-EZ04SS-055	68	55	-	10	14.5	-	4	17	-	-	0.15
	HSK-E025-EZ04SS-070	68	70	-	10	16	-	4	17	-	-	0.20
	HSK-E025-EZ05SS-045	68	45	-	11	14.5	-	5	17	-	-	0.10
STOCK	CODE	FIG.	L1	L2	ØD1	ØD2	ØD3	Ød	I1-min. 最短夾持長度 Min. Clamping Length	I2-max. 最長夾持長度 Max. Clamping Length	止動螺絲 (M) Screw Page 153	重量 (KG) Weight
	HSK-E032-EZ03SS-040	68	40	-	9	13	-	3	15	-	-	0.15
	HSK-E032-EZ03SS-070	68	70	-	9	16	-	3	15	-	-	0.20
	HSK-E032-EZ04SS-040	68	40	-	10	14	-	4	17	-	-	0.15
	HSK-E032-EZ04SS-070	68	70	-	10	17	-	4	17	-	-	0.20
STOCK	CODE	FIG.	L1	L2	ØD1	ØD2	ØD3	Ød	I1-min. 最短夾持長度 Min. Clamping Length	I2-max. 最長夾持長度 Max. Clamping Length	止動螺絲 (M) Screw Page 153	重量 (KG) Weight
	HSK-E040-EZ03SS-060	68	60	-	9	14	-	3	15	-	-	0.30
	HSK-E040-EZ03SS-070	68	70	-	9	15	-	3	15	-	-	0.40
	HSK-E040-EZ03SS-080	68	80	-	9	16	-	3	15	-	-	0.50
	HSK-E040-EZ04SS-060	68	60	-	10	15	-	4	17	-	-	0.30
	HSK-E040-EZ04SS-070	68	70	-	10	16	-	4	17	-	-	0.40
	HSK-E040-EZ04SS-080	68	80	-	10	17	-	4	17	-	-	0.50
	HSK-E040-EZ05SS-060	68	60	-	11	16	-	5	17	-	-	0.30
	HSK-E040-EZ05SS-070	68	70	-	11	17	-	5	17	-	-	0.40
	HSK-E040-EZ05SS-080	68	80	-	11	18	-	5	17	-	-	0.50
STOCK	CODE	FIG.	L1	L2	ØD1	ØD2	ØD3	Ød	I1-min. 最短夾持長度 Min. Clamping Length	I2-max. 最長夾持長度 Max. Clamping Length	止動螺絲 (M) Screw Page 153	重量 (KG) Weight
	HSK-E050-EZ03SS-070	68	70	-	9	14	-	3	15	-	-	0.50
	HSK-E050-EZ03SS-080	68	80	-	9	15	-	3	15	-	-	0.60
	HSK-E050-EZ03SS-100	68	100	-	9	17	-	3	15	-	-	0.80
	HSK-E050-EZ04SS-070	68	70	-	10	15	-	4	17	-	-	0.50
	HSK-E050-EZ04SS-080	68	80	-	10	16	-	4	17	-	-	0.60
	HSK-E050-EZ04SS-100	68	100	-	10	18	-	4	17	-	-	0.80
	HSK-E050-EZ05SS-070	68	70	-	11	16	-	5	17	-	-	0.50
	HSK-E050-EZ05SS-080	68	80	-	11	17	-	5	17	-	-	0.60
	HSK-E050-EZ05SS-100	68	100	-	11	19	-	5	17	-	-	0.80

STOCK ◎=標準在庫品 // STOCK ○=regular stock | STOCK ○=少量在庫品 // STOCK ○=few stock | STOCK無標示=接單生產品 // STOCK BLANK=on request

HSK-E-EZSS

■ SlimSuper shrink fit chucks

● 超細型熱膨脹燒結刀桿

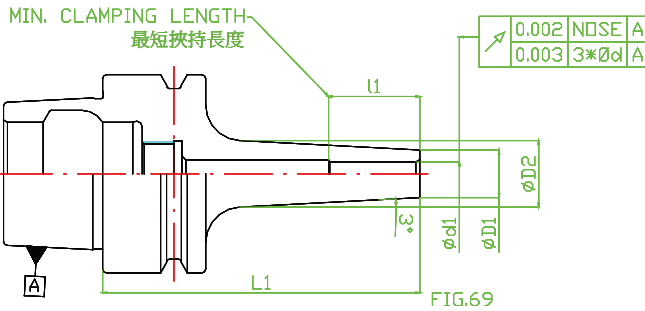

動平衡G2.5/25,000RPM或小於1gmm // BALANCE TO G2.5/25,000RPM OR UNDER 1gmm

STOCK	CODE	FIG.	L1	L2	ØD1	ØD2	ØD3	Ød	I1-min. 最短夾持長度 Min. Clamping Length	I2-max. 最長夾持長度 Max. Clamping Length	止動螺絲 (M) Screw Page 153	重量 (KG) Weight
	HSK-E025-EZ06SS-045	69	45	-	12	15.5	-	6	23	-	-	0.15
	HSK-E025-EZ06SS-070	69	70	-	12	18	-	6	23	-	-	0.20
	HSK-E025-EZ08SS-050	69	50	-	14	18	-	8	27	-	-	0.15
	HSK-E025-EZ08SS-070	69	70	-	14	18	-	8	27	-	-	0.20
	HSK-E025-EZ10SS-050	69	50	-	16	19	-	10	32	-	-	0.15
	HSK-E025-EZ10SS-070	69	70	-	16	19	-	10	32	-	-	0.20
STOCK	CODE	FIG.	L1	L2	ØD1	ØD2	ØD3	Ød	I1-min. 最短夾持長度 Min. Clamping Length	I2-max. 最長夾持長度 Max. Clamping Length	止動螺絲 (M) Screw Page 153	重量 (KG) Weight
	HSK-E032-EZ06SS-050	69	50	-	12	17	-	6	23	-	-	0.20
	HSK-E032-EZ06SS-080	69	80	-	12	20	-	6	23	-	-	0.30
	HSK-E032-EZ08SS-050	69	50	-	14	19	-	8	27	-	-	0.20
	HSK-E032-EZ08SS-080	69	80	-	14	22	-	8	27	-	-	0.30
	HSK-E032-EZ10SS-055	69	55	-	16	21	-	10	32	-	-	0.20
	HSK-E032-EZ10SS-080	69	80	-	16	22	-	10	32	-	-	0.30
STOCK	CODE	FIG.	L1	L2	ØD1	ØD2	ØD3	Ød	I1-min. 最短夾持長度 Min. Clamping Length	I2-max. 最長夾持長度 Max. Clamping Length	止動螺絲 (M) Screw Page 153	重量 (KG) Weight
	HSK-E040-EZ06SS-060	69	60	-	12	17	-	6	23	-	-	0.40
	HSK-E040-EZ06SS-070	69	70	-	12	18	-	6	23	-	-	0.50
	HSK-E040-EZ06SS-080	69	80	-	12	19	-	6	23	-	-	0.60
	HSK-E040-EZ06SS-114	69	114	-	12	21	-	6	23	-	-	0.80
	HSK-E040-EZ06SS-144	69	144	-	12	24	-	6	23	-	-	1.00
	HSK-E040-EZ08SS-060	69	60	-	14	19	-	8	27	-	-	0.40
	HSK-E040-EZ08SS-070	69	70	-	14	20	-	8	27	-	-	0.50
	HSK-E040-EZ08SS-080	69	80	-	14	21	-	8	27	-	-	0.60
	HSK-E040-EZ08SS-114	69	114	-	14	23	-	8	27	-	-	0.80
	HSK-E040-EZ08SS-144	69	144	-	14	26	-	8	27	-	-	1.00
	HSK-E040-EZ10SS-060	69	60	-	16	21	-	10	32	-	-	0.40
	HSK-E040-EZ10SS-070	69	70	-	16	22	-	10	32	-	-	0.50
	HSK-E040-EZ10SS-080	69	80	-	16	23	-	10	32	-	-	0.60
	HSK-E040-EZ10SS-114	69	114	-	16	25	-	10	32	-	-	0.80
	HSK-E040-EZ10SS-144	69	144	-	16	28	-	10	32	-	-	1.00
	HSK-E040-EZ12SS-060	69	60	-	18	23	-	12	37	-	-	0.40
	HSK-E040-EZ12SS-070	69	70	-	18	24	-	12	37	-	-	0.50
	HSK-E040-EZ12SS-080	69	80	-	18	25	-	12	37	-	-	0.60
	HSK-E040-EZ12SS-114	69	114	-	18	27	-	12	37	-	-	0.80
	HSK-E040-EZ12SS-144	69	144	-	18	30	-	12	37	-	-	1.00

STOCK ◎=標準在庫品 // STOCK ○=regular stock | STOCK ◯=少量在庫品 // STOCK ◯=few stock | STOCK無標示=接單生產品 // STOCK BLANK=on request

■ SlimSuper shrink fit chucks

● 超細型熱膨脹燒結刀桿

動平衡G2.5/25,000RPM或小於1gmm // BALANCE TO G2.5/25,000RPM OR UNDER 1gmm

STOCK	CODE	FIG.	L1	L2	ØD1	ØD2	ØD3	Ød	l1-min. 最短夾持長度 Min. Clamping Length	l2-max. 最長夾持長度 Max. Clamping Length	止動螺絲 (M) Screw Page 153	重量 (KG) Weight
	HSK-E050-EZ06SS-070	69	70	-	12	17	-	6	23	-	-	0.50
	HSK-E050-EZ06SS-080	69	80	-	12	18	-	6	23	-	-	0.60
	HSK-E050-EZ06SS-100	69	100	-	12	20	-	6	23	-	-	0.80
	HSK-E050-EZ06SS-120	69	120	-	12	21	-	6	23	-	-	1.00
	HSK-E050-EZ06SS-150	69	150	-	12	24	-	6	23	-	-	1.20
	HSK-E050-EZ08SS-070	69	70	-	14	19	-	8	27	-	-	0.50
	HSK-E050-EZ08SS-080	69	80	-	14	20	-	8	27	-	-	0.60
	HSK-E050-EZ08SS-100	69	100	-	14	22	-	8	27	-	-	0.80
	HSK-E050-EZ08SS-120	69	120	-	14	23	-	8	27	-	-	1.00
	HSK-E050-EZ08SS-150	69	150	-	14	26	-	8	27	-	-	1.20
	HSK-E050-EZ10SS-070	69	70	-	16	21	-	10	32	-	-	0.50
	HSK-E050-EZ10SS-080	69	80	-	16	22	-	10	32	-	-	0.60
	HSK-E050-EZ10SS-100	69	100	-	16	24	-	10	32	-	-	0.80
	HSK-E050-EZ10SS-120	69	120	-	16	25	-	10	32	-	-	1.00
	HSK-E050-EZ10SS-150	69	150	-	16	28	-	10	32	-	-	1.20
	HSK-E050-EZ12SS-070	69	70	-	18	23	-	12	37	-	-	0.50
	HSK-E050-EZ12SS-080	69	80	-	18	24	-	12	37	-	-	0.60
	HSK-E050-EZ12SS-100	69	100	-	18	26	-	12	37	-	-	0.80
	HSK-E050-EZ12SS-120	69	120	-	18	27	-	12	37	-	-	1.00
	HSK-E050-EZ12SS-150	69	150	-	18	30	-	12	37	-	-	1.20

STOCK ◎=標準在庫品 // STOCK ⊙=regular stock | STOCK ○=少量在庫品 // STOCK ◯=few stock | STOCK無標示=接單生產品 // STOCK BLANK=on request

HSK-E-SGER

SGER power ER collet chucks

SGER 強力型 ER 筒夾刀桿

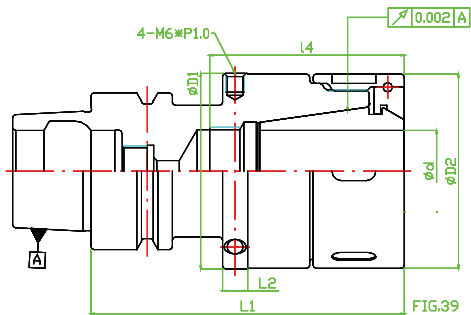
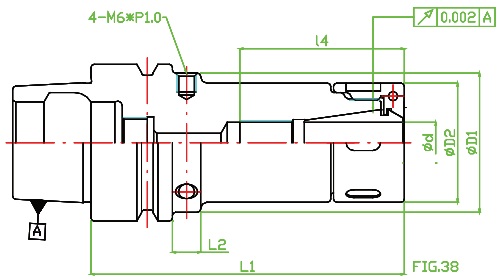

動平衡G2.5/25,000RPM或小於1gmm // BALANCE TO G2.5/25,000RPM OR UNDER 1gmm

STOCK	CODE	FIG.	L1	L2	L3	I4	D1	D2	d	止動螺絲 (M) Screw Page 154	筒夾 COLLET Page 143	螺帽 NUT Page 151	扳手 WRENCH Page 154	重量 (KG) Weight
	HSK-E032-SGER16-070	39	70	8	-	-	34.4	34	0.5~10.0	-	ER16	N16SGX nano	W-FK04	0.50
	HSK-E032-SGER20-070	39	70	8	-	-	38.4	38	0.5~13.0	-	ER20	N20SGX nano	W-FK05	0.60
	HSK-E032-SGER25-070	39	70	8	-	-	44.4	44	0.5~16.0	-	ER25	N25SGX nano	W-FK06	0.70
STOCK	CODE	FIG.	L1	L2	L3	I4	D1	D2	d	止動螺絲 (M) Screw Page 154	筒夾 COLLET Page 143	螺帽 NUT Page 151	扳手 WRENCH Page 154	重量 (KG) Weight
	HSK-E040-SGER16-070	39	70	8	-	-	34.4	34	0.5~10.0	-	ER16	N16SGX nano	W-FK04	0.50
	HSK-E040-SGER16-100	39	100	8	-	46	34.4	34	0.5~10.0	M11*P1.0	ER16	N16SGX nano	W-FK04	0.70
	HSK-E040-SGER20-070	39	70	8	-	-	38.4	38	0.5~13.0	-	ER20	N20SGX nano	W-FK05	0.60
	HSK-E040-SGER20-100	39	100	8	-	51	38.4	38	0.5~13.0	M14*P1.0	ER20	N20SGX nano	W-FK05	0.80
	HSK-E040-SGER25-070	39	70	8	-	-	44.4	44	0.5~16.0	-	ER25	N25SGX nano	W-FK06	0.70
	HSK-E040-SGER25-100	39	100	8	-	53	44.4	44	0.5~16.0	M18*P1.5	ER25	N25SGX nano	W-FK06	0.90
	HSK-E040-SGER32-070	39	70	8	-	-	52.4	52	2.0~20.0	-	ER32	N32SGX nano	W-FK08	0.80
	HSK-E040-SGER32-100	39	100	8	-	52	52.4	52	2.0~20.0	M24*P1.5	ER32	N32SGX nano	W-FK08	1.00
STOCK	CODE	FIG.	L1	L2	L3	I4	D1	D2	d	止動螺絲 (M) Screw Page 154	筒夾 COLLET Page 143	螺帽 NUT Page 151	扳手 WRENCH Page 154	重量 (KG) Weight
	HSK-E050-SGER16-070	38	70	9	-	-	38.4	34	0.5~10.0	-	ER16	N16SGX nano	W-FK04	0.70
	HSK-E050-SGER16-100	38	100	9	-	46	38.4	34	0.5~10.0	M11*P1.0	ER16	N16SGX nano	W-FK04	0.90
	HSK-E050-SGER20-070	38	70	9	-	-	38.4	34	0.5~10.0	-	ER20	N20SGX nano	W-FK04	0.80
	HSK-E050-SGER20-100	38	100	9	-	51	38.4	38	0.5~13.0	M14*P1.0	ER20	N20SGX nano	W-FK05	1.00
	HSK-E050-SGER25-080	39	80	8	-	-	44.4	44	0.5~16.0	-	ER25	N25SGX nano	W-FK06	0.90
	HSK-E050-SGER25-100	39	100	8	-	53	44.4	44	0.5~16.0	M18*P1.5	ER25	N25SGX nano	W-FK06	1.10
	HSK-E050-SGER32-080	39	80	8	-	-	52.4	52	2.0~20.0	-	ER32	N32SGX nano	W-FK08	1.00
	HSK-E050-SGER32-100	39	100	8	-	52	52.4	52	2.0~20.0	M24*P1.5	ER32	N32SGX nano	W-FK08	1.20
	HSK-E050-SGER40-080	39	80	8	-	-	62.4	62	3.0~26.0	-	ER40	N40SGX nano	W-FK09	1.60
	HSK-E050-SGER40-100	39	100	8	-	-	62.4	62	3.0~26.0	-	ER40	N40SGX nano	W-FK09	1.90

產品FIG.38 & 39出貨附件為高速平衡奈米鋼珠螺帽

NxxSGX nano*1pc // PRODUCTS IN FIG.38 & 39 EQUIP WITH BALANCED NANO BALL BEARING NUT NxxSGX nano*1pc

STOCK ◎=標準在庫品 // STOCK ○=regular stock | STOCK ◯=少量在庫品 // STOCK ◯=few stock | STOCK無標示=接單生產品 // STOCK

BLANK=on request

ER筒夾和扳手是另購品 // ER COLLET AND WRENCH TO BE ORDERED SEPARATELY

ERM nut collet chucks & ER collet chucks

ERM 型螺帽筒夾刀桿 & ER 筒夾刀桿

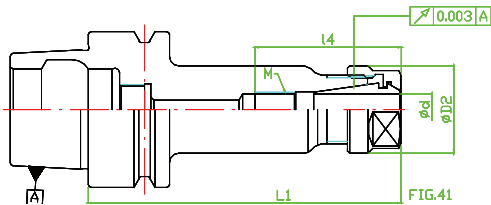
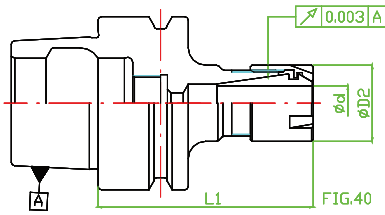

動平衡G2.5/25,000RPM或小於1gmm // BALANCE TO G2.5/25,000RPM OR UNDER 1gmm

STOCK	CODE	FIG.	L1	L2	L3	I4	D1	D2	d	止動螺絲 (M) Screw Page 154	筒夾 COLLET Page 143	螺帽 NUT Page 151	扳手 WRENCH Page 154	重量 (KG) Weight
	HSK-E025-ER16M-044	40	44	-	-	-	-	22	0.5~10.0	-	ER16	N16MX nano	W-ER16M	0.30
STOCK	CODE	FIG.	L1	L2	L3	I4	D1	D2	d	止動螺絲 (M) Screw Page 154	筒夾 COLLET Page 143	螺帽 NUT Page 151	扳手 WRENCH Page 154	重量 (KG) Weight
	HSK-E032-ER16M-060	40	60	-	-	-	-	22	0.5~10.0	-	ER16	N16MX nano	W-ER16M	0.40
	HSK-E032-ER20M-060	40	60	-	-	-	-	28	0.5~13.0	-	ER20	N20MX nano	W-ER20M	0.50
STOCK	CODE	FIG.	L1	L2	L3	I4	D1	D2	d	止動螺絲 (M) Screw Page 154	筒夾 COLLET Page 143	螺帽 NUT Page 151	扳手 WRENCH Page 154	重量 (KG) Weight
	HSK-E040-ER20M-065	40	65	-	-	-	-	28	0.5~13.0	-	ER20	N20MX nano	W-ER20M	0.50
	HSK-E040-ER25M-080	40	80	-	-	-	-	35	0.5~16.0	-	ER25	N25MX nano	W-ER25M	0.70
	HSK-E040-ER11-060	41	60	-	-	-	-	19	0.5~7.0	-	ER11	N11SX nano	W-ER11	0.40
	HSK-E040-ER16-060	41	60	-	-	-	-	28	0.5~10.0	-	ER16	N16SX nano	W-ER16	0.50
	HSK-E040-ER16-080	41	80	-	-	-	-	28	0.5~10.0	-	ER16	N16SX nano	W-ER16	0.60
	HSK-E040-ER25-070	41	70	-	-	-	-	42	0.5~16.0	-	ER25	N25SX nano	W-FK06	0.70
	HSK-E040-ER25-080	41	80	-	-	-	-	42	0.5~16.0	-	ER25	N25SX nano	W-FK06	0.80
STOCK	CODE	FIG.	L1	L2	L3	I4	D1	D2	d	止動螺絲 (M) Screw Page 154	筒夾 COLLET Page 143	螺帽 NUT Page 151	扳手 WRENCH Page 154	重量 (KG) Weight
	HSK-E050-ER16-060	41	60	-	-	-	-	28	0.5~10.0	-	ER16	N16SX nano	W-ER16	0.60
	HSK-E050-ER16-100	41	100	-	-	46	-	28	0.5~10.0	M11*P1.0	ER16	N16SX nano	W-ER16	0.90
	HSK-E050-ER25-070	41	70	-	-	-	-	42	0.5~16.0	-	ER25	N25SX nano	W-FK06	0.80
	HSK-E050-ER25-100	41	100	-	-	53	-	42	0.5~16.0	M18*P1.5	ER25	N25SX nano	W-FK06	1.10
	HSK-E050-ER32-080	41	80	-	-	-	-	50	2.0~20.0	-	ER32	N32SX nano	W-FK08	1.00
	HSK-E050-ER32-100	41	100	-	-	52	-	50	2.0~20.0	M24*P1.5	ER32	N32SX nano	W-FK08	1.20

產品FIG.40出貨附件為高速平衡奈米螺帽NxxMX nano*1pc // PRODUCTS IN FIG.40 EQUIP WITH BALANCED NANO NUT NxxMX nano*1pc

產品FIG.41出貨附件為高速平衡奈米螺帽NxxSX nano*1pc // PRODUCTS IN FIG.41 EQUIP WITH BALANCED NANO NUT NxxSX nano*1pc

STOCK ◎=標準在庫品 // STOCK ◎=regular stock | STOCK ○=少量在庫品 // STOCK ○=few stock | STOCK無標示=按單生產 // STOCK

BLANK=on request

ER筒夾和扳手是另購品 // ER COLLET AND WRENCH TO BE ORDERED SEPARATELY